

# SERVO GLAS 4000



CE EN175  
EN379  
**ANSI** Z87.1

## User's Manual

Auto-Darkening Welding Helmet  
SERVO GLAS® 4000

ANSI CE



**SERVORE** 써보레 | #406 Woolim e-Biz Center, 170-5 Guro-dongGuro-gu, Seoul City, Korea.  
TEL : +82-2-861-6691/2 ◆ FAX : +82-2-861-6693  
SERVORE CO. Home page: www.servore.com ◆ E-mail: servore@servore.com

**SERVORE**  
www.servore.com



## Instructions for use of SERVO GLAS® 4000

Thank you for purchasing a Servo Glas® 4000 welding helmet.



Note

For your own protection, safety and to ensure the maximum service life of your new helmet please read this manual carefully before use. Misuse or abuse may result in injury or reduced protection and may also void your warranty.

Safety is a personal responsibility. Servore endeavours to produce high quality safety products that meet or exceed relevant Standards and provide appropriate protection when used properly. Please help yourself and those around you by using this product carefully and by exercising good judgement. Thank you.

### 1. Before Use

#### 1-1 Servo Glas® 4000

The auto darkening welding filter in the SV4000 has been designed for arc welding and gas cutting. It is suitable for all normal arc welding processes such as MIG, MAG, TIG, SMAW, Plasma Arc and Air Carbon welding.

Before use the shade control should be adjusted to the appropriate level based upon EN169 (European Standard specifications or equivalent) or other appropriate safety guidelines. When in doubt please consult your safety representative or your authorized Servo Glas® 4000 distributor. The Servo Glas® 4000 provides continuous protection from ultraviolet and infrared radiation to the maximum level indicated on the product and as described in the relevant Standards. This protection is fail-safe and is not compromised by loss of battery power or other electronic failure.

The Servo Glas® 4000 welding filter cartridge is fitted with two independently operated sensors that detect the welding arc and respond accordingly resulting in the appropriate darkened filter state as set by the user and as indicated on the scaled adjustment. Please note that professional judgement may be required to achieve the best results. When in doubt consult an authorized safety representative or your Servo Glas® distributor and always maintain a conservative attitude towards operation.

Two replaceable lithium batteries type CR2032 (3V) are used as major power sources. An additional solar cell panel extends battery life and ensures efficient operation. When operating normally the welding helmet will switch on automatically and switch off automatically to save power a few minutes after the last welding arc has been detected.

To provide a general check of system status you may wish to set the shade control to 11 and hold the helmet towards a bright incandescent light source. Under normal circumstances the filter will change from light to dark state and back to light state again as you move the helmet away. Please note that if you have any questions or there is any doubt about the performance of your Servore product you should refer to your authorized safety representative or Servo Glas® distributor.

#### 1-2 Helmet and Head harness Adjustment

Please make the appropriate adjustment(s) to the head harness to ensure a comfortable and secure fit. It only takes a minute and helps ensure you are properly protected. The ServoGlas® 4000 harness allows you to adjust the distance and angle between your eyes and the filter window. You can also adjust the circumference of the headband to ensure a comfortable but firm fit. Please make these adjustments before use based on the illustrations in figures shown below.

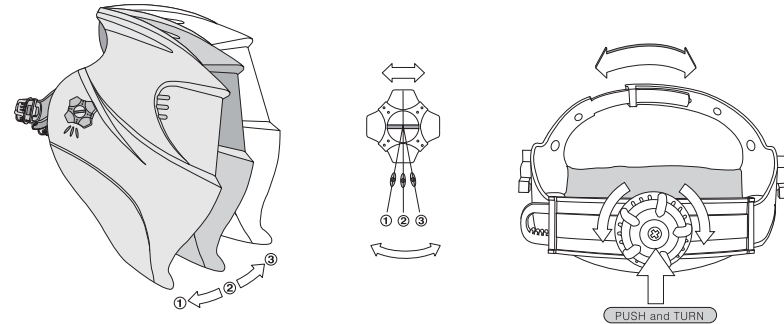

Note

- Genuine Servo Glas® front and inside cover plates must always be used with Servo Glas® 4000 welding filter and helmet. Failure to do so may result in injury and also void any warranty.
- Servo Glas® 4000 is not designed for use in overhead welding applications where additional protection may be required.
- Check for normal operation of the auto-darkening welding filter. If the welding filter does not darken in use stop welding immediately.
- Always select the appropriate shade before use according to the type of welding and current/amperes required. When in doubt refer to your authorized safety representative.



## 2. Markings

The appropriate available shade number markings and range are indicated on the product. Please ensure that the appropriate shade number is selected before welding. Used properly the ServoGlas® 4000 provides eye and face protection to meet or exceed EN379 and EN175 and other relevant Standards where indicated. The following example illustrates these requirements. Please note this example is provided for illustration purposes only.

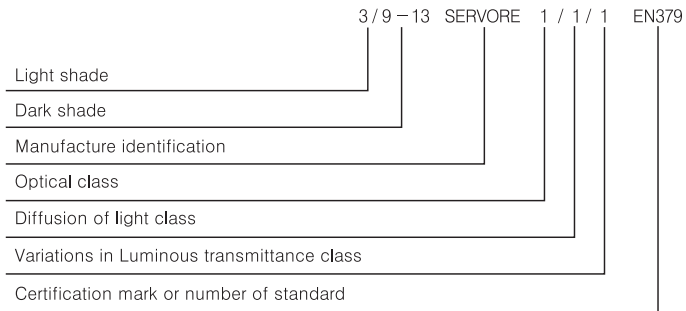

## 3. Parts List

The following parts are available from Servore and your authorized ServoGlas® 4000 distributor.

Part No.	Description
1	Helmet Shell
2	Front Cover Plate(122X86mm)
3	Magnifying Lens
4	Welding Filter Cartridge
4-1	Auto-darkening Welding Filter
4-2	Guide Frame
4-3	Battery Case
5	Inside Cover Plate(110X47mm)
6	Head Band
7	Helmet Knob

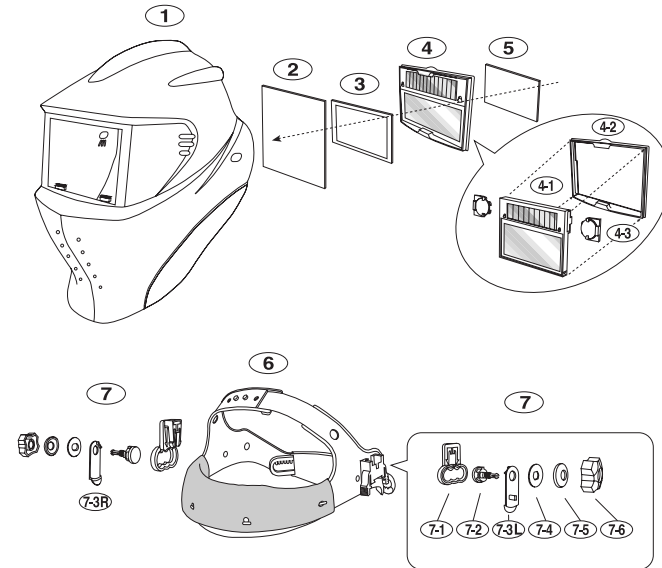

### Helmet Knob Parts

Part No.	Description	Helmet Adjustment
7-1	Band Holder	<p>Move P-bolt back and forth to adjust the helmet distance between eyes and filter window.</p>
7-2	P-Bolt	
7-3L	Angular Stopper L	
7-3R	Angular Stopper R	
7-4	Angular Washer	
7-5	Wahser	
7-6	Knob	



#### 4. Technical Specifications

Switching time (light-dark)	0.05 msec - TIG welding (Pre-shading Tech.)	
	0.06 msec - ARC, MIG, MAG welding	
Delay switch (dark-light)	Slow : 0.3-0.6s Fast : 0.1-0.35s	
Light transmitting	Inactivated	Light shade #3
	Activated	Dark shade #9 ~ #13
Sensitivity control	Adjustable	
UV/IR Protection	Up to shade #13	
Power source	Lithium battery 3V 2ea + Solar cells	
	Power Auto On / Off	
Battery life	3 years (Typical)	
Filter cartridge size	118 × 83mm (4.65 × 3.26 in)	
Viewing area	104 × 42mm (4.00 × 0.15in)	
Filter cartridge weight	115 g (4 oz)	
Product total weight	429 g (15 oz)	
Operating temp.	-5°C ~ +55°C	
Storage temp.	-20°C ~ +70°C	
Warranty	2 year on auto-darkening filter cartridge only	

#### 5. Control Function

##### PARTS

- |                        |                  |                     |
|------------------------|------------------|---------------------|
| 1. Solar Cell Panel    | 2. Sensor        | 3. LCD Filter Plate |
| 4. Sensitivity Control | 5. Shade Control | 6. Delay Switch     |
| 7. Low Battery Lamp    |                  |                     |

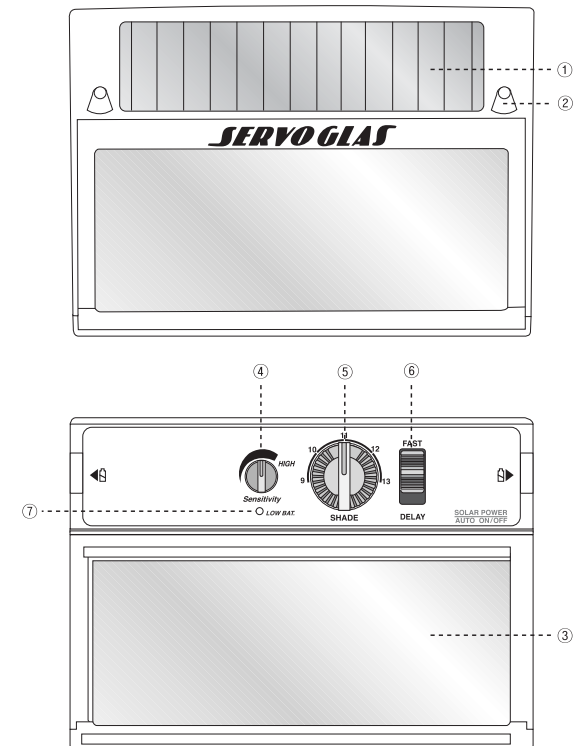



### 5-1. Shade Control

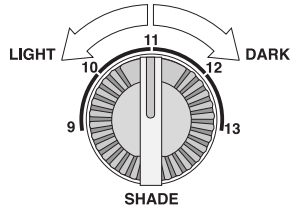

The required filter dark state can be selected by using the shade control. The ServoGlas® 4000 can be adjusted between shades 9 to 13 with the embossed arrow on the dial indicating the current adjustment.

Always use the appropriate shade for the welding operation you are undertaking. When in doubt please consult the relevant Standards or your authorized safety representative.

Recommended shade numbers according to BS 679, DIN 4647-1 and EN169

Welding process	Current in amperes																							
	0.5	2.5	10	20	40	80	125	175	225	275	350	450	1	5	15	30	60	100	150	200	250	300	400	500
Covered electrodes				9	10	11	12	13	14															
MIG on heavy metals				10	11	12	13	14																
MIG light alloys				10	11	12	13	14	15															
TIG on all metals and alloys	9	10	11	12	13	14																		
MAG				10	11	12	13	14	15															
Arc-air gouging				10	11	12	13	14	15															
Plasma jet cutting				11	12	13																		
Micropasma arc welding	2.5	3	4	5	6	7	8	9	10	11	12	13	14	15										

According to the conditions of use, the next greater or the next smaller scale number can be used.

### 5-2. Light Sensitivity Control



Where problems are experienced during welding at low currents [e.g. TIG] or there is a high level of ambient light please follow these steps: First try adjusting the sensitivity control switch. If this does not solve the problem hold the helmet close to the target object and adjust the shade control completely clockwise. If the welding filter continues in the bright state, leave the control set at this point. If the filter changes to the dark state, turn the shade adjustment knob until the filter just switches into the light state. The filter will then be adjusted correctly. If the welding filter still does not respond appropriately please try adjusting the sensitivity control again (having previously adjusted the shade control as explained above)

### 5-3. Delay Control



Adjustment of the speed at which the welding filter clears can be reduced by means of the delay control toggle switch. When this switch is set to 'Fast' the screen will clear more quickly.



## 6. Maintenance



Note

Always ensure that all maintenance procedures are conducted in a clean dry place.  
Use clean dry hands and avoid direct contact with any glass surfaces.  
Handle cover plates and welding filter by the edges and carefully clean off any dirt or debris before re-use.

### 6-1. Replacement of Front Cover Plate

To replace the front cover plate, the filter cartridge must be removed from the recess in the helmet. Unlock the either side of cartridge holders pushing upward.

After removing the filter cartridge from the recess in the helmet, gently push out the old plate. Ensure that the protective plastic film is removed from both sides of the new cover plate and that it is clean and free of any scratches. Carefully slot the new plate into the recess in the helmet.

After replacing the welding filter cartridge into the helmet, lock it into place with the retaining clip(s).

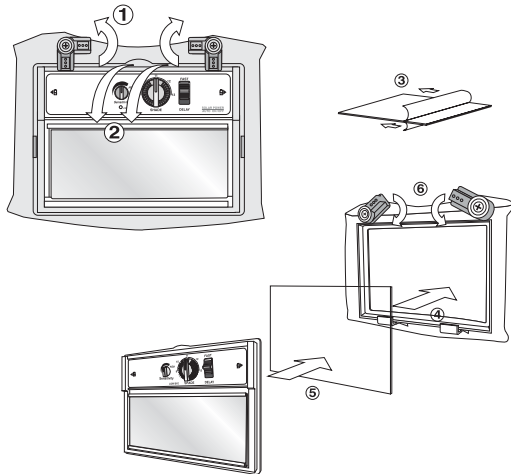

### 6-2. Replacement of Inside Cover Plate

To replace the protective inside cover plate the filter cartridge must be removed from the retaining guide frame. Always ensure this process is conducted in a clean dry place and take care not to drop the filter cartridge. To remove the filter cartridge from the retaining frame gently expand the frame, you can then separate and remove the cartridge from the frame.

You will now be able to slide out the inside cover plate as shown in the diagrams.

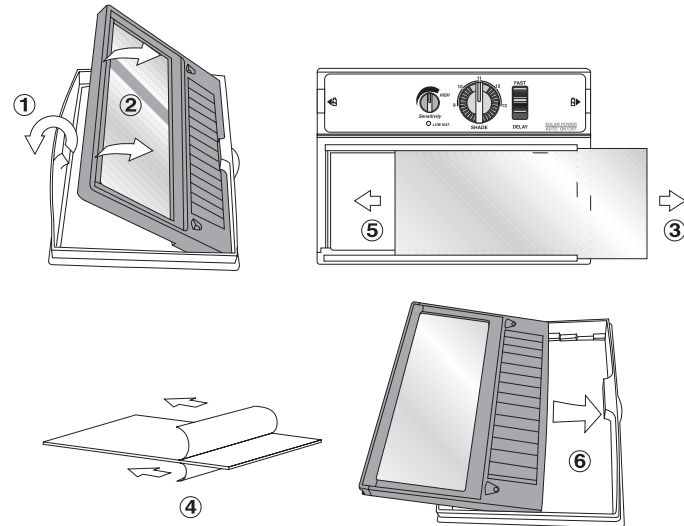

Note

Never use the helmet without a front and inside cover plate installed.  
Never use a helmet without a filter cartridge installed



#### 6-4. Replacement of Battery

The Servo Glas® 4000 uses two batteries to provide backup power. Always replace both batteries at the same time. Batteries should be replaced either: (a) Every three years or when the low battery warning lamp turns on (please also remove batteries and store them separately if the helmet is to be stored for a long time.) (b) When the speed at which the filter darkens decreases or when the density of the darkness of the screen is reduced or uneven.

To replace the batteries, remove the filter from the retaining guide frame as explained in 6-3. You will then be able to slide out the battery cases on either side of the cartridge and replace the batteries as shown in diagrams below.

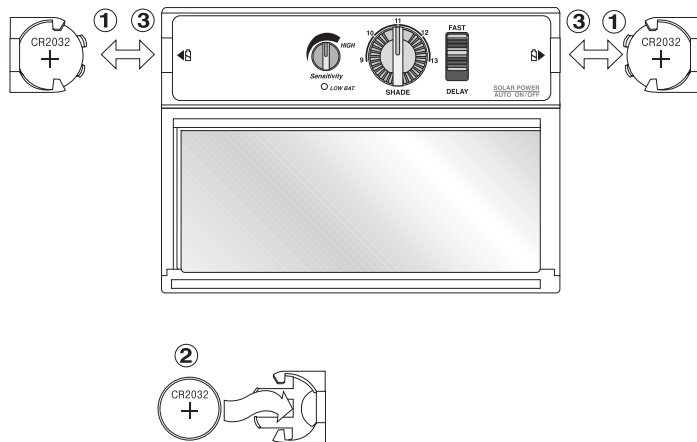

Note

Always use good quality batteries of the correct type and be careful to ensure they are inserted in the correct manner paying careful attention to battery polarity.

#### 7. Storage and Temperature Range

Your Servore welding helmet is strong and durable. It is designed to work in temperatures between -5C and +55C. Do not use your helmet in very hot conditions where temperatures exceed +65C. Always store your helmet in a clean dry place out of the direct sun and protect it from exposure to moisture or extreme heat (min/max storage temperature is -20C ~ +70C).

Avoid unnecessary impact or compression of your helmet and never use a helmet that is damaged. Your Servore welding helmet is a quality professional tool and careful storage will extend the life of your investment.

#### 8. Inspection

Check your helmet shell and filter on a regular basis when in normal use and after extended periods of storage. Never use a cracked or damaged helmet as this may result in personal injury and will void your warranty.

Please replace any worn or damaged parts as necessary.

Genuine Servo Glas® replacement parts are available from your authorized Servo Glas® distributor.

#### 9. Cleaning



Note

Never expose the filter cartridge to direct contact with water or solvents.

After removing the welding filter from the shell the shell can be cleaned using a mild detergent and water solution. Sweat bands can be washed. A silicone based lubricant may be used on moving parts if necessary but is not normally required. The filter may be carefully wiped with a cloth dampened with household window cleaning solution. Please be careful not to scratch or otherwise damage the filter cartridge with fragments of welding spatter or other abrasive dirt. Refer to the relevant parts diagram for illustrations regarding assembly and disassembly.



## 10. Cautions



### Cautions

- The Servo Glas® 4000 is designed for personal eye and face protection from harmful radiation, sparks and welding spatter produced under normal welding conditions. Please follow good industry and safety practices and use additional protection where necessary.
- Cover plates are strong and of industry standard quality but they are breakable. The Servo Glas® 4000 is a quality welding helmet but is not designed to provide protection from severe impact such as broken grinding wheels or debris from other broken tools, corrosive liquids, explosions, or other extreme incidents. We recommend you always adopt a conservative attitude towards safety and take additional precautions as required and recommended in the relevant safety standards relating to the operation you are undertaking.
- The welding filter is not designed to be waterproof. Please do not use your helmet in the rain or other inclement weather. To do so may reduce the life of your helmet and result in damage or injury.
- In the event that your helmet or welding filter is exposed to direct contact with, or is submerged in water or other liquid immediately stop using the helmet, remove the filter cartridge from the shell, remove the batteries from the filter, inspect carefully for damage and if necessary mop-up excess moisture with a paper towel and then leave to dry in a warm (not hot) place out of direct sunlight. Never place your helmet in an oven or microwave to dry. Before use perform all normal system checks and if in any doubt contact your Servo Glas® distributor. Your Servore helmet is a precision engineered professional protection product and must be maintained in good condition to ensure your personal protection.



### Cautions

- When working in the vicinity of other welders it is necessary to adopt good industry standard practice and ensure a minimum distance of 1M between workers. Failure to do so may result in injury or malfunction of the auto darkening mechanism.
- Please do not wear the helmet when you are not welding. In some circumstances the auto darkening mechanism may be unexpectedly triggered resulting in reduced vision and subsequent injury to yourself or others.
- Servore does not support the use of Servo Glas® 4000 range of products in combination with any other manufacturers' products. To use parts that are not approved by Servore may void your warranty and result in personal injury. Please use only genuine Servo Glas® 4000 parts and spares as provided by your authorized Servo Glas® distributor.
- Servore reserves the right to make improvements, change or otherwise modify the specifications, materials and design of any and all Servore products at their sole discretion with a view to ensuring continuous improvement. Never attempt any unauthorized modifications or alterations to your Servore product. To do so may result in personal injury and void your warranty.

Thank you for purchasing a Servore product. If you have any questions regarding this or any other Servore product please contact your authorized Servo Glas® distributor.